

A250 Limit Switch Boxes

Proval A250 Series limit switch boxes are used on rotary valve actuators to generate open/close signal and monitor the valve position.

Technical Specifications,

- * 3D continuous visual position indicator
- * Easy adjustable spring forced CAM system
- * Standard IP67 enclosure
- * 2 pcs Open/Close mechanical or proximity switches
- * Easy adjustable brackets and suitable for all NAMUR VDI/VDE interface actuators
- * 8 strips on terminal box allows direct connection of solenoid valve inside the switch box.

Optional,

- * Ex d II B T6 Explosion Proof Type

Material List

Part Name	Material
Body	Powder Epoxy Coated Aluminum Injection
Indicator	Transparent Plastic
Bolt	AISI316 Stainless Steel
Stem	AISI316 Stainless Steel
Seal Ring	EPDM

Mounting Bracket Dimensions (mm)

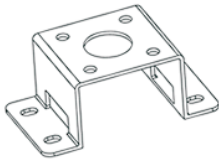
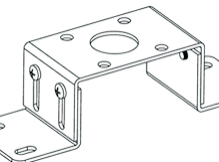
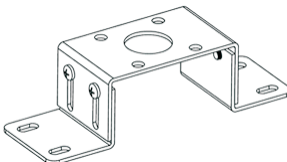
Model	Bracket Type	Mounting Dimensions
MB-1		30x80 H:20
MB-2		30x80 H:30
MB-3		30x130 H:30-50 (H size is adjustable)

Technical Specifications

Product Code	Enclosure	Working Temp.	Cable Gland	Terminal	Position Indicator	Switch Type
A250 PSM	IP67	-20°C ~ +80°C	2 x G1/2	8 Strips	3D View 0 ~ 90° Open-Close	Mechanical
A250 PSP	IP67	-20°C ~ +80°C	2 x G1/2	8 Strips	3D View 0 ~ 90° Open-Close	Inductive (Proximity)



A250 PSM Limit Switch Box

Dimensions of A250 PSM Limit Switch Box

